

Air and Aerodynamics and Flight Vocabulary

Air pressure- the amount of air placed in or around an object

Air resistance- the amount of air that pushes against an object

Air Flow- the direction in which air moves past an object

Expand- when an object takes up more space

Compression (compress)- air pressed into a smaller space

Accelerate- speed up

Decelerate- slow down

Aerodynamics- the study of air and how it moves around objects.

Bernoulli's Principle- moving air has less pressure than still air

Law of Flight: objects go from high pressure to low pressure.

Newton's Third Law: if there is a force in one direction, there is an equal force in the opposite direction

Glider: a plane that does not have an engine. They rely on thermals (upward air currents) to provide lift.

Forces in Flight

Lift- upward force

Gravity- downward force

Drag- backwards force

Thrust- forward force

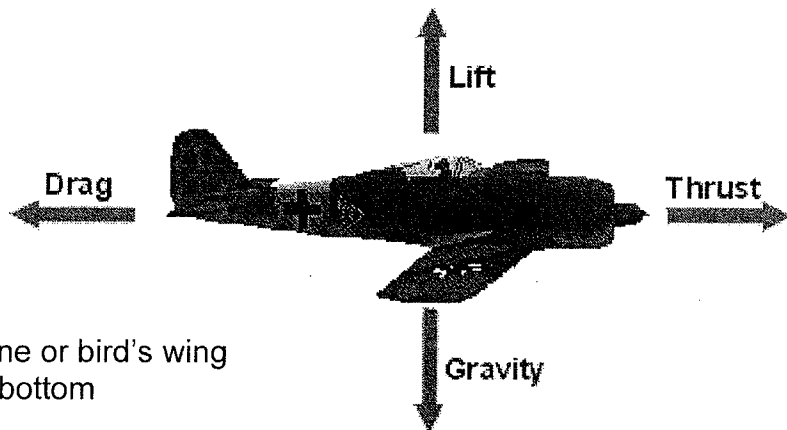

Airfoil- the shape of an airplane or bird's wing
Curved on top and flat on the bottom

Parts and Movements of a plane

Fuselage- main part of the plane; where passengers, crew and cargo are

Propeller- moves the plane through the air

Jet engines- take in air, compress it, then the air is forced out

Ailerons; flaps on the wings of a plane tht move up of down: do not need to move together. Control the roll of a plane

Roll- when one wing dips lower than the other; movement is up or down of horizontal

Elevators- flaps on the tail of a plane; move together. Control the pitch of a plane

Pitch- when a plane moves up or down. Movement is vertical.

Rudder- the flap on the tail of a plane that turns the plane laterally left or right; controls the yaw.

Yaw- when a plane turns left or right; movement is lateral

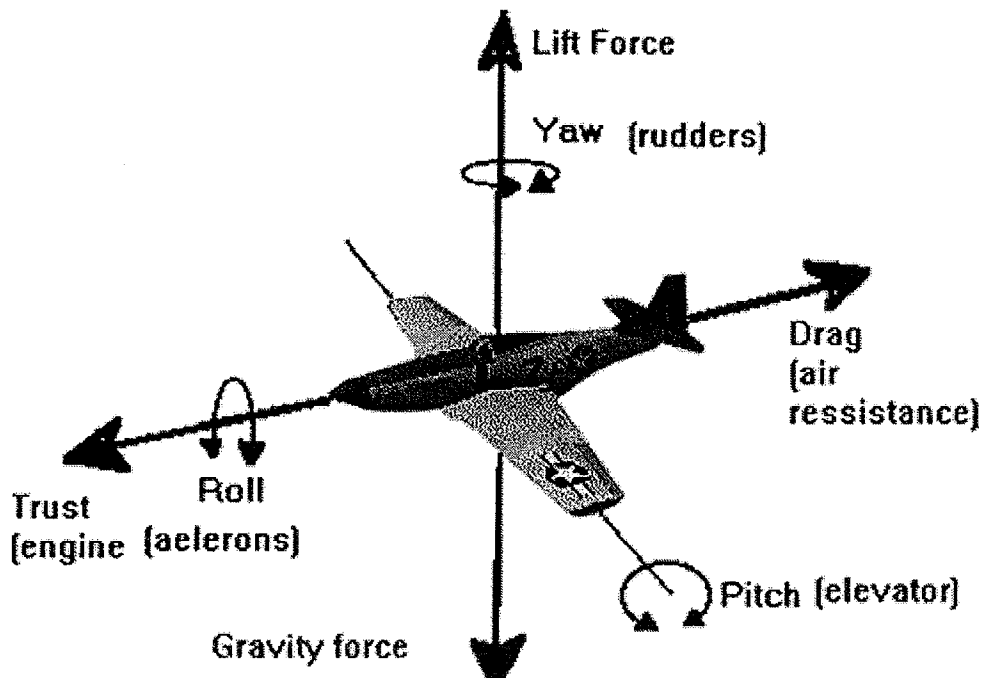

Air and Aerodynamics Study guide

Air – the air we breathe is made of different gases

Gas	Percent in Air
Nitrogen	79 %
Oxygen	21 %
Argon	1 %
Other trace gases	Less than 1%

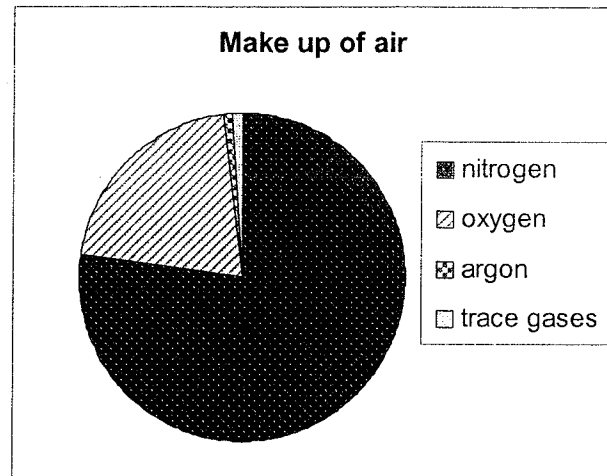

Air exists because:

- ◆ It takes up space
- ◆ It has volume
- ◆ It has weight
- ◆ Air has mass
- ◆ It has pressure

Air takes up space

- ◆ Run a garbage bag through the air- it fills with air = air takes up the space in the bag
- ◆ Put a cup upside down in water. The cup will not fill with water because air is taking the space up in the cup. You must let the air out (by tipping the cup) in order for water to fill up the space.

Air has volume

- ◆ You can measure the volume of air in a room- take the measurements of the room (length X width X height). This will equal the volume of air in the room.

Air has weight

- ◆ tie two equal size balloons on the ends of a stick. Balance them. Pop one balloon. The other balloon filled with air will fall towards the ground because it has weight.

Air has mass

- ◆ measure a balloon that is not blown up on a scale. Record its mass. Blow up the balloon with air. Remeasure the balloon on the scale. The difference is the mass of the air

Air has pressure

- ◆ air pressure increases the closer you are to sea level
- ◆ air pressure decreases as you go up a mountain.

Air	Higher or Lower Pressure
Cold air	higher
Warm air	lower
Still air	higher
Moving air	lower

Bernoulli's principle states that faster flowing fluids (gases and liquids) have lower pressure than slower flowing fluids

Hot Air Balloons

- Hot air balloons work because hot air rises. Blowing hot air into the envelope of the balloon makes the air in the balloon less dense. Once the air in the balloon is less dense than the outside air, the balloon will rise (it is more buoyant).
- Hot air balloons use the blower to create lift and the air currents to create thrust.
- Air balloons are controlled by the slits in the envelope- opening the slits causes the balloon to descend.

Aerodynamics is the study of air and how it moves around objects
To make objects more aerodynamics:

- you can study how air moves around the object in a wind tunnel
Objects that are aerodynamic tend to be rounder (curved) and lighter.

Forces in Flight

Lift- upward force

Gravity- downward force

Drag- backwards force

Thrust- forward force

Force	Opposite force	Greater force = What happens
lift	gravity	Lift is greater = plane will go up Gravity is greater = plane will go down
thrust	drag	Thrust is greater = plane will speed up Drag is greater = plane will slow down

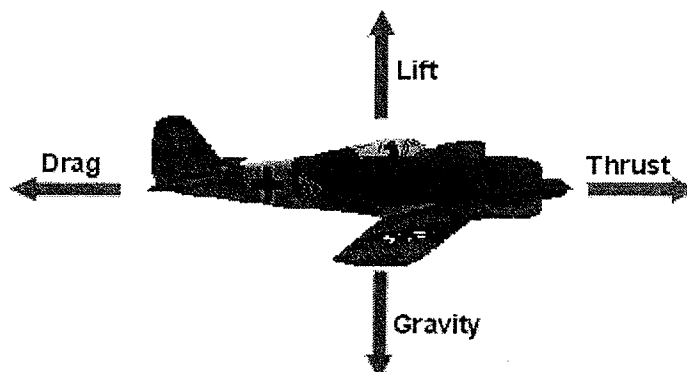

Parts of a Plane

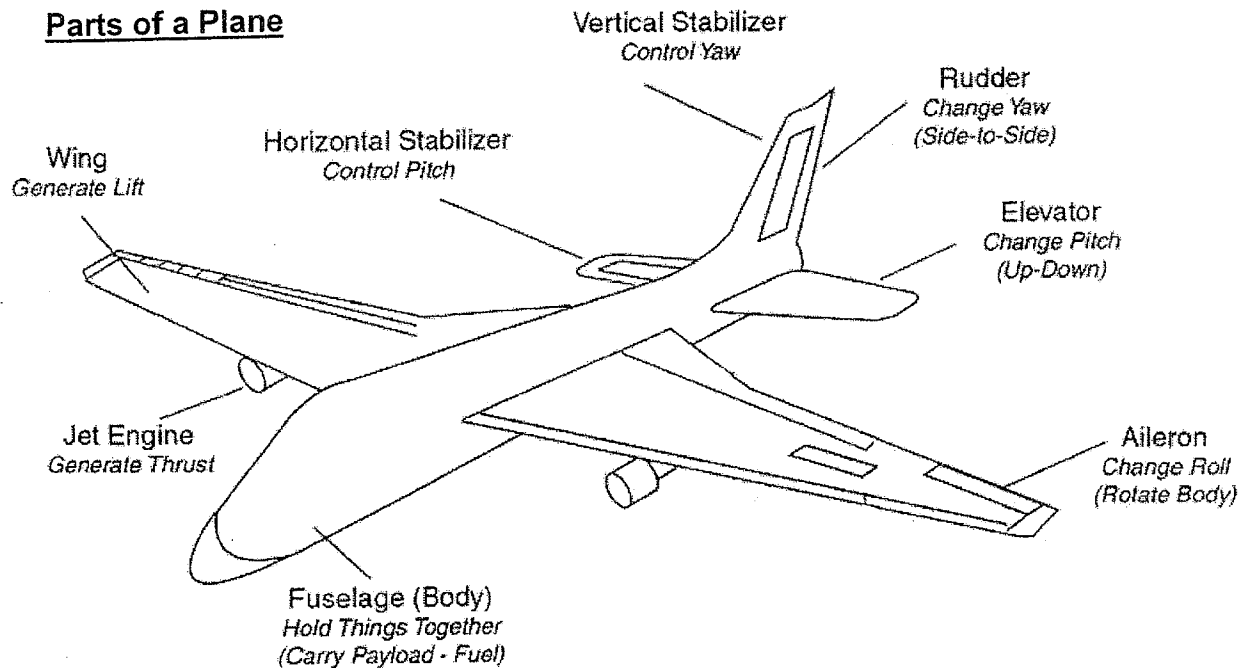

Parachutes

Parachutes work by increasing drag. The design of a parachute will determine how fast it falls and lands and if you can maneuver in the air.

A large canopy will increase drag

A wide narrow canopy will allow for greater control in the air.

Airfoils

Air foils are curved on the top and flat on the bottom. Air moves faster over the top of the airfoil than on the bottom. The air on the top of the airfoil has low pressure and the air on the bottom, because it is moving slower, has high pressure. This creates lift.

Things that fly

Birds and insects have special adaptations for flight

Birds	Insects
<ul style="list-style-type: none"> • have hollow bones that make them lightweight but strong 	<ul style="list-style-type: none"> • Light weight and small
<ul style="list-style-type: none"> • Have feathers 	<ul style="list-style-type: none"> • May have one or two sets of wings
<ul style="list-style-type: none"> • Have strong pectoral muscles that allow them to flap their wings 	<ul style="list-style-type: none"> • Have strong pectoral muscles that allow them to move wings
<ul style="list-style-type: none"> • Wings shaped like an airfoil 	<ul style="list-style-type: none"> • Wings shaped like an airfoil
<ul style="list-style-type: none"> • Aerodynamic shape 	<ul style="list-style-type: none"> • Aerodynamic shape
<ul style="list-style-type: none"> • Primary and secondary feathers each have a role in flight. Primaries allow the bird to maneuver in the air. Secondaries catch air. 	<ul style="list-style-type: none"> • Wings are very thin with a network of veins. Veins make the wings very strong.

